

# Graduate Aptitude Test in Engineering 2017

**Question Paper Name:** Civil Engineering 12th Feb 2017 Session 1  
**Subject Name:** Civil Engineering  
**Duration:** 180  
**Total Marks:** 100



## Organizing Institute: Indian Institute of Technology Roorkee



**Question Number : 1****Correct : 1 Wrong : -0.33**

The matrix  $\mathbf{P}$  is the inverse of a matrix  $\mathbf{Q}$ . If  $\mathbf{I}$  denotes the identity matrix, which one of the following options is correct?

- (A)  $\mathbf{PQ} = \mathbf{I}$  but  $\mathbf{QP} \neq \mathbf{I}$
- (B)  $\mathbf{QP} = \mathbf{I}$  but  $\mathbf{PQ} \neq \mathbf{I}$
- (C)  $\mathbf{PQ} = \mathbf{I}$  and  $\mathbf{QP} = \mathbf{I}$
- (D)  $\mathbf{PQ} - \mathbf{QP} = \mathbf{I}$

**Question Number : 2****Correct : 1 Wrong : -0.33**

The number of parameters in the univariate exponential and Gaussian distributions, respectively, are

- (A) 2 and 2
- (B) 1 and 2
- (C) 2 and 1
- (D) 1 and 1

**Question Number : 3****Correct : 1 Wrong : -0.33**

Let  $x$  be a continuous variable defined over the interval  $(-\infty, \infty)$ , and  $f(x) = e^{-x} - e^{-x}$ .

The integral  $g(x) = \int f(x) dx$  is equal to

- (A)  $e^{e^{-x}}$
- (B)  $e^{-e^{-x}}$
- (C)  $e^{-e^x}$
- (D)  $e^{-x}$

**Question Number : 4****Correct : 1 Wrong : -0.33**

An elastic bar of length  $L$ , uniform cross sectional area  $A$ , coefficient of thermal expansion  $\alpha$ , and Young's modulus  $E$  is fixed at the two ends. The temperature of the bar is increased by  $T$ , resulting in an axial stress  $\sigma$ . Keeping all other parameters unchanged, if the length of the bar is doubled, the axial stress would be

- (A)  $\sigma$
- (B)  $2\sigma$
- (C)  $0.5\sigma$
- (D)  $0.25\alpha\sigma$

**Question Number : 5****Correct : 1 Wrong : -0.33**

A simply supported beam is subjected to a uniformly distributed load. Which one of the following statements is true?

- (A) Maximum or minimum shear force occurs where the curvature is zero.
- (B) Maximum or minimum bending moment occurs where the shear force is zero.
- (C) Maximum or minimum bending moment occurs where the curvature is zero.
- (D) Maximum bending moment and maximum shear force occur at the same section.

**Question Number : 6****Correct : 1 Wrong : -0.33**

According to IS 456 – 2000, which one of the following statements about the depth of neutral axis  $x_{u,bal}$  for a balanced reinforced concrete section is correct?

- (A)  $x_{u,bal}$  depends on the grade of concrete only.
- (B)  $x_{u,bal}$  depends on the grade of steel only.
- (C)  $x_{u,bal}$  depends on both the grade of concrete and grade of steel.
- (D)  $x_{u,bal}$  does not depend on the grade of concrete and grade of steel.

**Question Number : 7****Correct : 1 Wrong : -0.33**

The figure shows a two-hinged parabolic arch of span  $L$  subjected to a uniformly distributed load of intensity  $q$  per unit length.

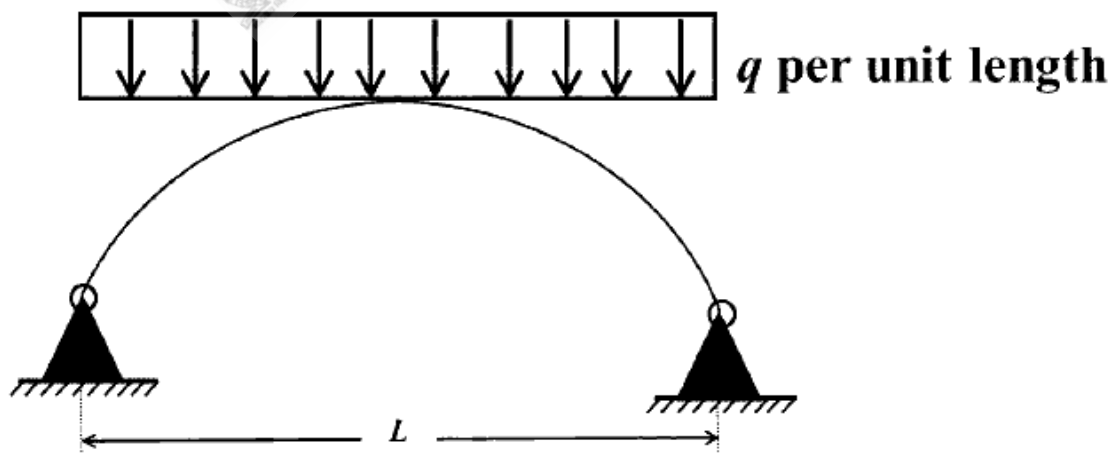

The maximum bending moment in the arch is equal to

- (A)  $\frac{qL^2}{8}$
- (B)  $\frac{qL^2}{12}$
- (C) zero
- (D)  $\frac{qL^2}{10}$

**Question Number : 8****Correct : 1 Wrong : -0.33**

Group I lists the type of gain or loss of strength in soils. Group II lists the property or process responsible for the loss or gain of strength in soils.

Group I

- P. Regain of strength with time
- Q. Loss of strength due to cyclic loading
- R. Loss of strength due to upward seepage
- S. Loss of strength due to remolding

Group II

- 1. Boiling
- 2. Liquefaction
- 3. Thixotropy
- 4. Sensitivity

The correct match between Group I and Group II is

- (A) P-4, Q-1, R-2, S-3
- (C) P-3, Q-2, R-1, S-4

- (B) P-3, Q-1, R-2, S-4
- (D) P-4, Q-2, R-1, S-3

**Question Number : 9****Correct : 1 Wrong : -0.33**

A soil sample is subjected to a hydrostatic pressure,  $\sigma$ . The Mohr circle for any point in the soil sample would be

- (A) a circle of radius  $\sigma$  and center at the origin
- (B) a circle of radius  $\sigma$  and center at a distance  $\sigma$  from the origin
- (C) a point at a distance  $\sigma$  from the origin
- (D) a circle of diameter  $\sigma$  and center at the origin

**Question Number : 10****Correct : 1 Wrong : -0.33**

A strip footing is resting on the ground surface of a pure clay bed having an undrained cohesion  $c_u$ . The ultimate bearing capacity of the footing is equal to

- (A)  $2\pi c_u$
- (B)  $\pi c_u$
- (C)  $(\pi+1) c_u$
- (D)  $(\pi+2) c_u$

**Question Number : 11****Correct : 1 Wrong : -0.33**

A uniformly distributed line load of 500 kN/m is acting on the ground surface. Based on Boussinesq's theory, the ratio of vertical stress at a depth 2 m to that at 4 m, right below the line of loading, is

- (A) 0.25
- (B) 0.5
- (C) 2.0
- (D) 4.0

**Question Number : 12****Correct : 1 Wrong : -0.33**

For a steady incompressible laminar flow between two infinite parallel stationary plates, the shear stress variation is

- (A) linear with zero value at the plates      (B) linear with zero value at the center  
(C) quadratic with zero value at the plates      (D) quadratic with zero value at the center

**Question Number : 13****Correct : 1 Wrong : -0.33**

The reaction rate involving reactants  $A$  and  $B$  is given by  $-k[A]^\alpha[B]^\beta$ . Which one of the following statements is valid for the reaction to be a first-order reaction?

- (A)  $\alpha = 0$  and  $\beta = 0$       (B)  $\alpha = 1$  and  $\beta = 0$       (C)  $\alpha = 1$  and  $\beta = 1$       (D)  $\alpha = 1$  and  $\beta = 2$

**Question Number : 14****Correct : 1 Wrong : -0.33**

The wastewater from a city, containing a high concentration of biodegradable organics, is being steadily discharged into a flowing river at a location  $S$ . If the rate of aeration of the river water is lower than the rate of degradation of the organics, then the dissolved oxygen of the river water

- (A) is lowest at the location  $S$ .  
(B) is lowest at a point upstream of the location  $S$ .  
(C) remains constant all along the length of the river.  
(D) is lowest at a point downstream of the location  $S$ .

**Question Number : 15****Correct : 1 Wrong : -0.33**

Which one of the following is NOT present in the acid rain?

- (A)  $\text{HNO}_3$       (B)  $\text{H}_2\text{SO}_4$       (C)  $\text{H}_2\text{CO}_3$       (D)  $\text{CH}_3\text{COOH}$

**Question Number : 16****Correct : 1 Wrong : -0.33**

A super-elevation  $e$  is provided on a circular horizontal curve such that a vehicle can be stopped on the curve without sliding. Assuming a design speed  $v$  and maximum coefficient of side friction  $f_{max}$ , which one of the following criteria should be satisfied?

- (A)  $e \leq f_{max}$   
(B)  $e > f_{max}$   
(C) no limit on  $e$  can be set  
(D)  $e = \frac{1 - (f_{max})^2}{f_{max}}$

**Question Number : 17****Correct : 1 Wrong : -0.33**

A runway is being constructed in a new airport as per the International Civil Aviation Organization (ICAO) recommendations. The elevation and the airport reference temperature of this airport are 535 m above the mean sea level and 22.65°C, respectively. Consider the effective gradient of runway as 1%. The length of runway required for a design-aircraft under the standard conditions is 2000 m. Within the framework of applying sequential corrections as per the ICAO recommendations, the length of runway corrected for the temperature is

- (A) 2223 m                      (B) 2250 m                      (C) 2500 m                      (D) 2750 m

**Question Number : 18****Correct : 1 Wrong : -0.33**

The accuracy of an Electronic Distance Measuring Instrument (EDMI) is specified as  $\pm (a \text{ mm} + b \text{ ppm})$ . Which one of the following statements is correct?

- (A) Both  $a$  and  $b$  remain constant, irrespective of the distance being measured.  
(B)  $a$  remains constant and  $b$  varies in proportion to the distance being measured.  
(C)  $a$  varies in proportion to the distance being measured and  $b$  remains constant.  
(D) Both  $a$  and  $b$  vary in proportion to the distance being measured.

**Question Number : 19****Correct : 1 Wrong : -0.33**

The number of spectral bands in the Enhanced Thematic Mapper sensor on the remote sensing satellite Landsat-7 is

- (A) 64    (B) 10  
(C) 8    (D) 15

**Question Number : 20****Correct : 1 Wrong : 0**

Consider the following partial differential equation:

$$3 \frac{\partial^2 \phi}{\partial x^2} + B \frac{\partial^2 \phi}{\partial x \partial y} + 3 \frac{\partial^2 \phi}{\partial y^2} + 4\phi = 0$$

For this equation to be classified as parabolic, the value of  $B^2$  must be \_\_\_\_\_

Question Number : 21

Correct : 1 Wrong : 0

$\lim_{x \rightarrow 0} \left( \frac{\tan x}{x^2 - x} \right)$  is equal to \_\_\_\_\_

Question Number : 22

Correct : 1 Wrong : 0

A 3 m thick clay layer is subjected to an initial uniform pore pressure of 145 kPa as shown in the figure.

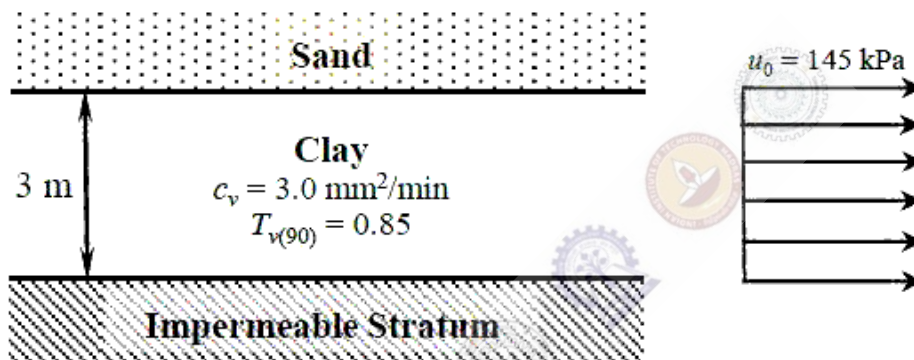

For the given ground conditions, the time (in days, rounded to the nearest integer) required for 90% consolidation would be \_\_\_\_\_

Question Number : 23

Correct : 1 Wrong : 0

A triangular pipe network is shown in the figure.

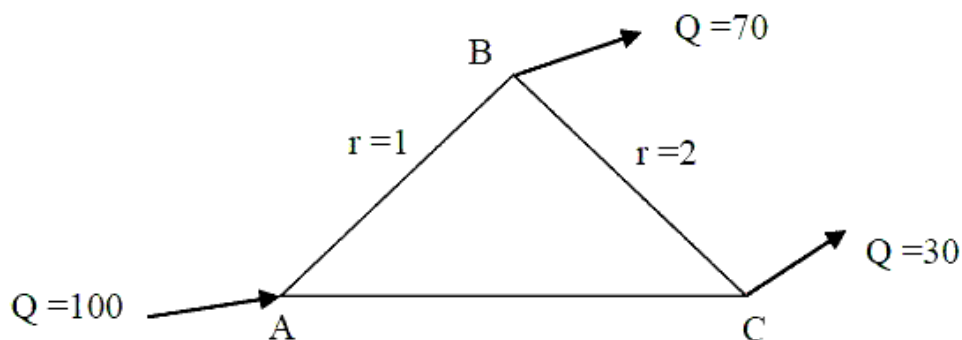

The head loss in each pipe is given by  $h_f = rQ^{1.8}$ , with the variables expressed in a consistent set of units. The value of  $r$  for the pipe  $AB$  is 1 and for the pipe  $BC$  is 2. If the discharge supplied at the point  $A$  (i.e., 100) is equally divided between the pipes  $AB$  and  $AC$ , the value of  $r$  (up to two decimal places) for the pipe  $AC$  should be \_\_\_\_\_

**Question Number : 24**

**Correct : 1 Wrong : 0**

The ordinates of a 2-hour unit hydrograph for a catchment are given as

Time (h)	0	1	2	3	4
Ordinate (m <sup>3</sup> /s)	0	5	12	25	41

The ordinate (in m<sup>3</sup>/s) of a 4-hour unit hydrograph for this catchment at the time of 3 h would be \_\_\_\_\_

**Question Number : 25**

**Correct : 1 Wrong : 0**

Vehicles arriving at an intersection from one of the approach roads follow the Poisson distribution. The mean rate of arrival is 900 vehicles per hour. If a gap is defined as the time difference between two successive vehicle arrivals (with vehicles assumed to be points), the probability (up to four decimal places) that the gap is greater than 8 seconds is \_\_\_\_\_

**Question Number : 26**

**Correct : 2 Wrong : -0.66**

For the function  $f(x) = a + bx$ ,  $0 \leq x \leq 1$ , to be a valid probability density function, which one of the following statements is correct?

(A)  $a = 1, b = 4$

(B)  $a = 0.5, b = 1$

(C)  $a = 0, b = 1$

(D)  $a = 1, b = -1$



**Question Number : 27**

**Correct : 2 Wrong : -0.66**

The solution of the equation  $\frac{dQ}{dt} + Q = 1$  with  $Q = 0$  at  $t = 0$  is

(A)  $Q(t) = e^{-t} - 1$

(B)  $Q(t) = 1 + e^{-t}$

(C)  $Q(t) = 1 - e^t$

(D)  $Q(t) = 1 - e^{-t}$

**Question Number : 28**

**Correct : 2 Wrong : -0.66**

Consider the matrix  $\begin{bmatrix} 5 & -1 \\ 4 & 1 \end{bmatrix}$ . Which one of the following statements is TRUE for the eigenvalues and eigenvectors of this matrix?

(A) Eigenvalue 3 has a multiplicity of 2, and only one independent eigenvector exists.

(B) Eigenvalue 3 has a multiplicity of 2, and two independent eigenvectors exist.

(C) Eigenvalue 3 has a multiplicity of 2, and no independent eigenvector exists.

(D) Eigenvalues are 3 and  $-3$ , and two independent eigenvectors exist.

Question Number : 29

Correct : 2 Wrong : -0.66

A planar truss tower structure is shown in the figure.

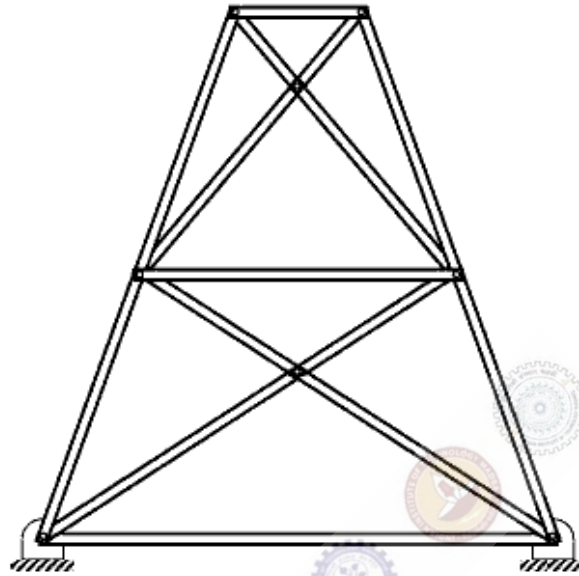

Consider the following statements about the external and internal determinacies of the truss.

- (P) Externally Determinate
- (Q) External Static Indeterminacy = 1
- (R) External Static Indeterminacy = 2
- (S) Internally Determinate
- (T) Internal Static Indeterminacy = 1
- (U) Internal Static Indeterminacy = 2

Which one of the following options is correct?

- (A) P-False; Q-True; R-False; S-False; T-False; U-True
- (B) P-False; Q-True; R-False; S-False; T-True; U-False
- (C) P-False; Q-False; R-True; S-False; T-False; U-True
- (D) P-True; Q-True; R-False; S-True; T-False; U-True

**Question Number : 30****Correct : 2 Wrong : -0.66**

Group I contains three broad classes of irrigation supply canal outlets. Group II presents hydraulic performance attributes.

Group I	Group II
P. Non-modular outlet	1. Outlet discharge depends on the water levels in both the supply canal as well as the receiving water course
Q. Semi-modular outlet	2. Outlet discharge is fixed and is independent of the water levels in both the supply canal as well as the receiving water course
R. Modular outlet	3. Outlet discharge depends only on the water level in the supply canal

The correct match of the items in Group I with the items in Group II is

- (A) P - 1; Q - 2; R - 3
- (B) P - 3; Q - 1; R - 2
- (C) P - 2; Q - 3; R - 1
- (D) P - 1; Q - 3; R - 2

**Question Number : 31****Correct : 2 Wrong : -0.66**

A 1 m wide rectangular channel has a bed slope of 0.0016 and the Manning's roughness coefficient is 0.04. Uniform flow takes place in the channel at a flow depth of 0.5 m. At a particular section, gradually varied flow (GVF) is observed and the flow depth is measured as 0.6 m. The GVF profile at that section is classified as

- (A)  $S_1$
- (B)  $S_2$
- (C)  $M_1$
- (D)  $M_2$

**Question Number : 32****Correct : 2 Wrong : -0.66**

The following observations are made while testing aggregate for its suitability in pavement construction:

- i. Mass of oven-dry aggregate in air = 1000 g
- ii. Mass of saturated surface-dry aggregate in air = 1025 g
- iii. Mass of saturated surface-dry aggregate under water = 625 g

Based on the above observations, the correct statement is

- (A) bulk specific gravity of aggregate = 2.5 and water absorption = 2.5%
- (B) bulk specific gravity of aggregate = 2.5 and water absorption = 2.4%
- (C) apparent specific gravity of aggregate = 2.5 and water absorption = 2.5%
- (D) apparent specific gravity of aggregate = 2.5 and water absorption = 2.4%

**Question Number : 33****Correct : 2 Wrong : -0.66**

The queue length (in number of vehicles) versus time (in seconds) plot for an approach to a signalized intersection with the cycle length of 96 seconds is shown in the figure (not drawn to scale).

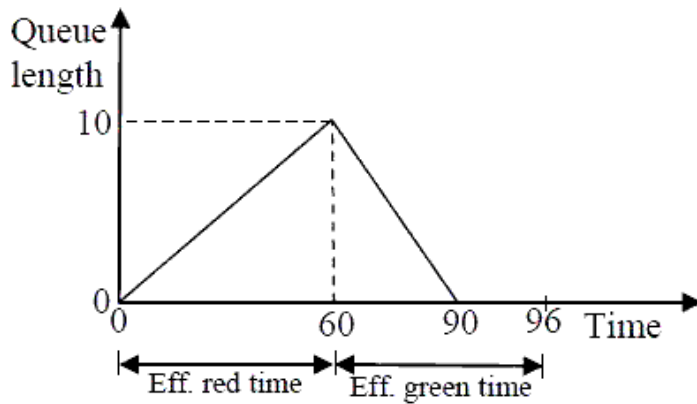

At time  $t = 0$ , the light has just turned red. The effective green time is 36 seconds, during which vehicles discharge at the saturation flow rate,  $s$  (in vph). Vehicles arrive at a uniform rate,  $v$  (in vph), throughout the cycle. Which one of the following statements is TRUE?

- (A)  $v = 600$  vph, and for this cycle, the average stopped delay per vehicle = 30 seconds
- (B)  $s = 1800$  vph, and for this cycle, the average stopped delay per vehicle = 28.125 seconds
- (C)  $v = 600$  vph, and for this cycle, the average stopped delay per vehicle = 45 seconds
- (D)  $s = 1200$  vph, and for this cycle, the average stopped delay per vehicle = 28.125 seconds

**Question Number : 34****Correct : 2 Wrong : -0.66**

The radius of a horizontal circular curve on a highway is 120 m. The design speed is 60 km/hour, and the design coefficient of lateral friction between the tyre and the road surface is 0.15. The estimated value of superelevation required (if full lateral friction is assumed to develop), and the value of coefficient of friction needed (if no superelevation is provided) will, respectively, be

- (A)  $\frac{1}{11.6}$  and 0.10
- (B)  $\frac{1}{10.5}$  and 0.37
- (C)  $\frac{1}{11.6}$  and 0.24
- (D)  $\frac{1}{12.9}$  and 0.24

**Question Number : 35****Correct : 2 Wrong : -0.66**

The observed bearings of a traverse are given below:

Line	Bearing	Line	Bearing
PQ	46°15'	QP	226°15'
QR	108°15'	RQ	286°15'
RS	201°30'	SR	20°30'
ST	321°45'	TS	141°45'

The station(s) most likely to be affected by the local attraction is/are

- (A) Only R                      (B) Only S                      (C) R and S                      (D) P and Q

**Question Number : 36****Correct : 2 Wrong : -0.66**

The laboratory tests on a soil sample yields the following results: natural moisture content = 18%, liquid limit = 60%, plastic limit = 25%, percentage of clay sized fraction = 25%.

The liquidity index and activity (as per the expression proposed by Skempton) of the soil, respectively, are

- (A) -0.2 and 1.4                      (B) 0.2 and 1.4  
 (C) -1.2 and 0.714                      (D) 1.2 and 0.714

**Question Number : 37****Correct : 2 Wrong : 0**

Consider the equation  $\frac{du}{dt} = 3t^2 + 1$  with  $u = 0$  at  $t = 0$ . This is numerically solved by using the forward Euler method with a step size,  $\Delta t = 2$ . The absolute error in the solution at the end of the first time step is \_\_\_\_\_

**Question Number : 38****Correct : 2 Wrong : 0**

A pre-tensioned rectangular concrete beam 150 mm wide and 300 mm depth is prestressed with three straight tendons, each having a cross-sectional area of  $50 \text{ mm}^2$ , to an initial stress of  $1200 \text{ N/mm}^2$ . The tendons are located at 100 mm from the soffit of the beam. If the modular ratio is 6, the loss of prestressing force (in kN, up to one decimal place) due to the elastic deformation of concrete only is \_\_\_\_\_

**Question Number : 39****Correct : 2 Wrong : 0**

Consider the stepped bar made with a linear elastic material and subjected to an axial load of 1 kN, as shown in the figure.

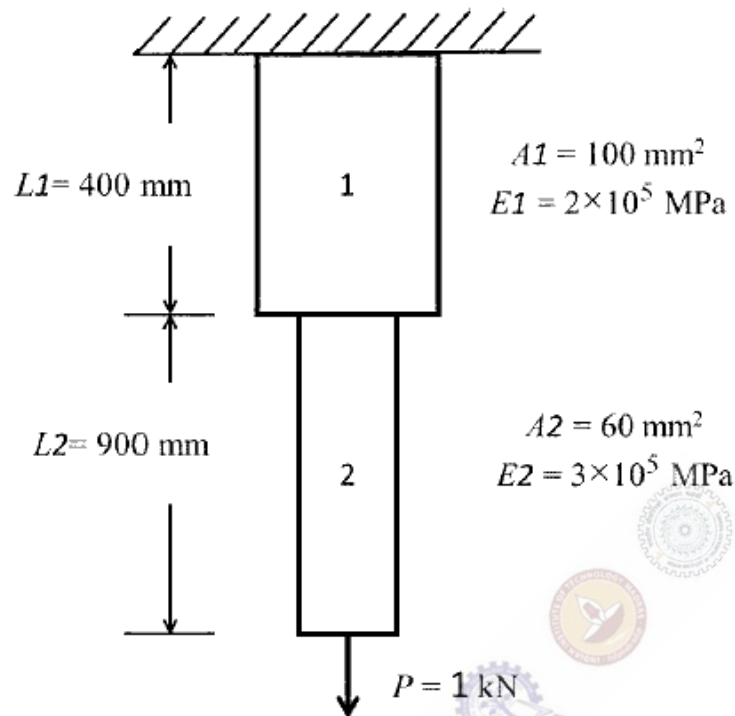

Segments 1 and 2 have cross-sectional area of  $100 \text{ mm}^2$  and  $60 \text{ mm}^2$ . Young's modulus of  $2 \times 10^5 \text{ MPa}$  and  $3 \times 10^5 \text{ MPa}$ , and length of 400 mm and 900 mm, respectively. The strain energy (in N-mm, up to one decimal place) in the bar due to the axial load is \_\_\_\_\_

**Question Number : 40****Correct : 2 Wrong : 0**

The value of  $M$  in the beam ABC shown in the figure is such that the joint B does not rotate.

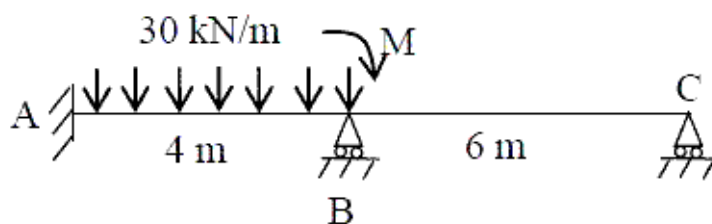

The value of support reaction (in kN) at B should be equal to \_\_\_\_\_

**Question Number : 41****Correct : 2 Wrong : 0**

Consider the beam ABCD shown in the figure.



For a moving concentrated load of 50 kN on the beam, the magnitude of the maximum bending moment (in kN-m) obtained at the support C will be equal to \_\_\_\_\_

**Question Number : 42****Correct : 2 Wrong : 0**

Consider two axially loaded columns, namely, 1 and 2, made of a linear elastic material with Young's modulus  $2 \times 10^5$  MPa, square cross-section with side 10 mm, and length 1 m. For Column 1, one end is fixed and the other end is free. For Column 2, one end is fixed and the other end is pinned. Based on the Euler's theory, the ratio (up to one decimal place) of the buckling load of Column 2 to the buckling load of Column 1 is \_\_\_\_\_

**Question Number : 43**

**Correct : 2 Wrong : 0**

A column is subjected to a load through a bracket as shown in the figure.

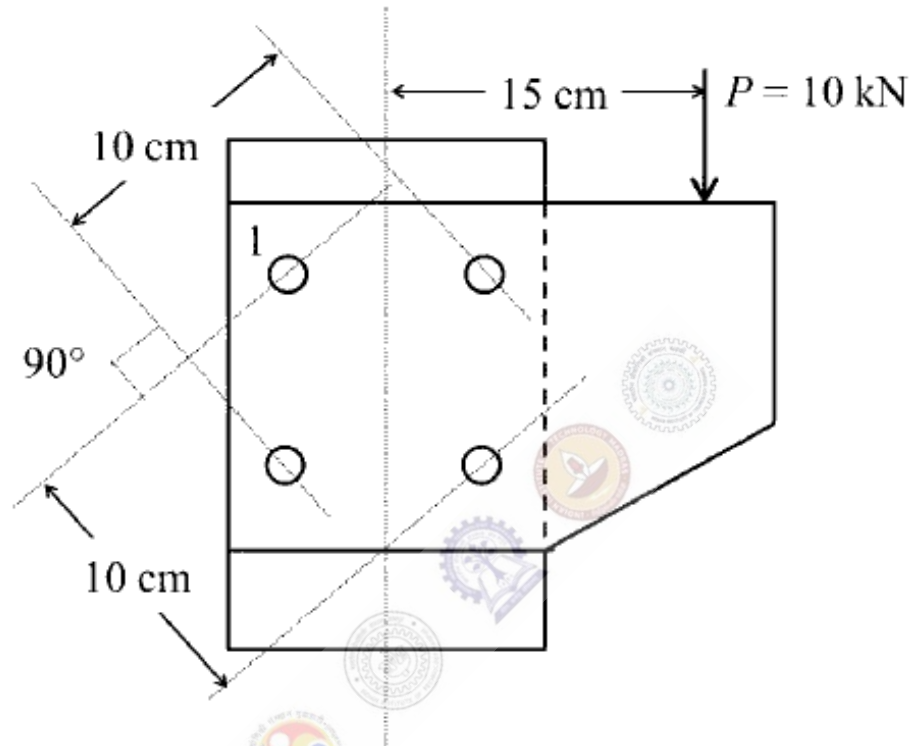

The resultant force (in kN, up to one decimal place) in the bolt 1 is \_\_\_\_\_

**Question Number : 44**

**Correct : 2 Wrong : 0**

A particle of mass 2 kg is travelling at a velocity of 1.5 m/s. A force  $f(t) = 3t^2$  (in N) is applied to it in the direction of motion for a duration of 2 seconds, where  $t$  denotes time in seconds. The velocity (in m/s, up to one decimal place) of the particle immediately after the removal of the force is \_\_\_\_\_



**Question Number : 45**

**Correct : 2 Wrong : 0**

The activity details of a project are given below:

Activity	Depends on	Duration (in days)
P	--	6
Q	P	15
R	Q, T	12
S	R	16
T	P	10
U	Q, T	14
V	U	16

The estimated minimum time (in days) for the completion of the project will be \_\_\_\_\_

**Question Number : 46**

**Correct : 2 Wrong : 0**

It is proposed to drive H-piles up to a depth of 7 m at a construction site. The average surface area of the H-pile is  $3 \text{ m}^2$  per meter length. The soil at the site is homogeneous sand, having an effective friction angle of  $32^\circ$ . The ground water table (GWT) is at a depth of 2 m below the ground surface. The unit weights of the soil above and below the GWT are  $16 \text{ kN/m}^3$  and  $19 \text{ kN/m}^3$ , respectively. Assume the earth pressure coefficient,  $K = 1.0$ , and the angle of wall friction,  $\delta = 23^\circ$ . The total axial frictional resistance (in kN, up to one decimal place) mobilized on the pile against the driving is \_\_\_\_\_

**Question Number : 47**

**Correct : 2 Wrong : 0**

The infinite sand slope shown in the figure is on the verge of sliding failure. The ground water table coincides with the ground surface. Unit weight of water  $\gamma_w = 9.81 \text{ kN/m}^3$ .

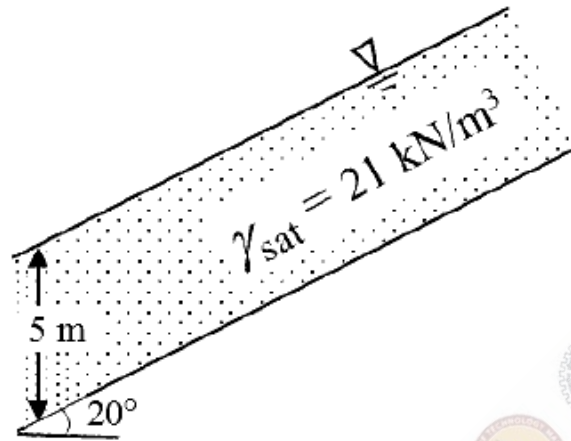

The value of the effective angle of internal friction (in degrees, up to one decimal place) of the sand is \_\_\_\_\_

**Question Number : 48**

**Correct : 2 Wrong : 0**

A sluice gate used to control the flow in a horizontal channel of unit width is shown in the figure.

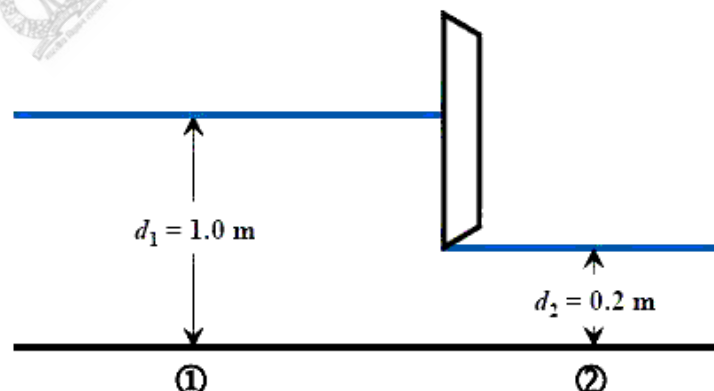

It is observed that the depth of flow is 1.0 m upstream of the gate, while the depth is 0.2 m downstream of the gate. Assuming a smooth flow transition across the sluice gate, i.e., without any energy loss, and the acceleration due to gravity as  $10 \text{ m/s}^2$ , the discharge (in  $\text{m}^3/\text{s}$ , up to two decimal places) passing under the sluice gate is \_\_\_\_\_

**Question Number : 49****Correct : 2 Wrong : 0**

Water flows through a 90° bend in a horizontal plane as depicted in the figure.

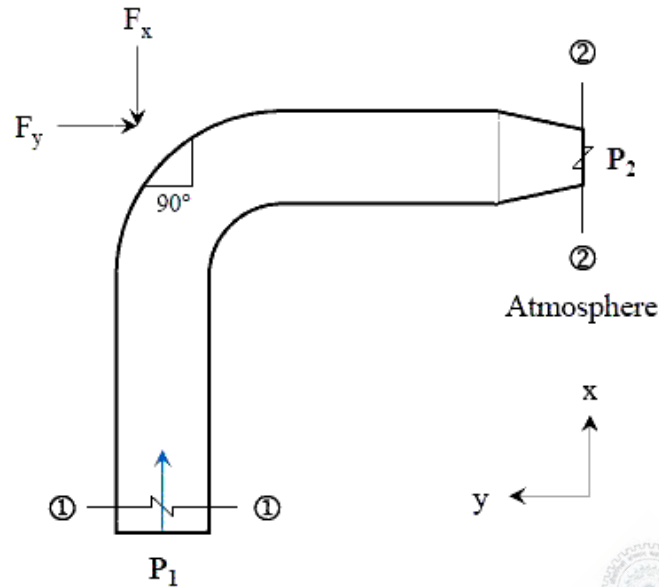

A pressure of 140 kPa is measured at Section 1-1. The inlet diameter marked at Section 1-1 is  $\frac{27}{\sqrt{\pi}}$  cm, while the nozzle diameter marked at Section 2-2 is  $\frac{14}{\sqrt{\pi}}$  cm. Assume the following:

- (i) Acceleration due to gravity = 10 m/s<sup>2</sup>.
- (ii) Weights of both the bent pipe segment as well as water are negligible.
- (iii) Friction across the bend is negligible.

The magnitude of the force (in kN, up to two decimal places) that would be required to hold the pipe section is \_\_\_\_\_

**Question Number : 50****Correct : 2 Wrong : 0**

A consolidated undrained ( $\overline{CU}$ ) triaxial compression test is conducted on a normally consolidated clay at a confining pressure of 100 kPa. The deviator stress at failure is 80 kPa, and the pore-water pressure measured at failure is 50 kPa. The effective angle of internal friction (in degrees, up to one decimal place) of the soil is \_\_\_\_\_

**Question Number : 51****Correct : 2 Wrong : 0**

An effective rainfall of 2-hour duration produced a flood hydrograph peak of  $200 \text{ m}^3/\text{s}$ . The flood hydrograph has a base flow of  $20 \text{ m}^3/\text{s}$ . If the spatial average rainfall in the watershed for the duration of storm is 2 cm and the average loss rate is 0.4 cm/hour, the peak of 2-hour unit hydrograph (in  $\text{m}^3/\text{s}\cdot\text{cm}$ , up to one decimal place) is \_\_\_\_\_

**Question Number : 52****Correct : 2 Wrong : 0**

The equivalent sound power level (in dB) of the four sources with the noise levels of 60 dB, 69 dB, 70 dB and 79 dB is \_\_\_\_\_

**Question Number : 53****Correct : 2 Wrong : 0**

The spherical grit particles, having a radius of 0.01 mm and specific gravity of 3.0, need to be separated in a settling chamber. It is given that

- $g = 9.81 \text{ m/s}^2$
- the density of the liquid in the settling chamber =  $1000 \text{ kg/m}^3$
- the kinematic viscosity of the liquid in the settling chamber =  $10^{-6} \text{ m}^2/\text{s}$

Assuming laminar conditions, the settling velocity (in mm/s, up to one decimal place) is \_\_\_\_\_

**Question Number : 54****Correct : 2 Wrong : 0**

Two wastewater streams A and B, having an identical ultimate BOD are getting mixed to form the stream C. The temperature of the stream A is  $20^\circ\text{C}$  and the temperature of the stream C is  $10^\circ\text{C}$ . It is given that

- the 5-day BOD of the stream A measured at  $20^\circ\text{C} = 50 \text{ mg/l}$
- BOD rate constant (base 10) at  $20^\circ\text{C} = 0.115 \text{ per day}$
- temperature coefficient = 1.135

The 5-day BOD (in mg/l, up to one decimal place) of the stream C, calculated at  $10^\circ\text{C}$ , is \_\_\_\_\_

**Question Number : 55**

**Correct : 2 Wrong : 0**

The wastewater having an organic concentration of 54 mg/l is flowing at a steady rate of 0.8 m<sup>3</sup>/day through a detention tank of dimensions 2 m × 4 m × 2 m. If the contents of the tank are well mixed and the decay constant is 0.1 per day, the outlet concentration (in mg/l, up to one decimal place) is \_\_\_\_\_

**Question Number : 56**

**Correct : 1 Wrong : -0.33**

The bacteria in milk are destroyed when it \_\_\_\_\_ heated to 80 degree Celsius.

(A) would be                      (B) will be                      (C) is                      (D) was

**Question Number : 57**

**Correct : 1 Wrong : -0.33**

\_\_\_\_\_ with someone else's email account is now a very serious offence.

(A) Involving                      (B) Assisting                      (C) Tampering                      (D) Incubating

**Question Number : 58**

**Correct : 1 Wrong : -0.33**

Consider the following sentences:

All benches are beds. No bed is a bulb. Some bulbs are lamps.

Which of the following can be inferred?

- i. Some beds are lamps.
- ii. Some lamps are beds.

(A) Only i

(C) Both i and ii

(B) Only ii

(D) Neither i nor ii

**Question Number : 59**

**Correct : 1 Wrong : -0.33**

If the radius of a right circular cone is increased by 50%. its volume increases by

(A) 75%

(B) 100%

(C) 125%

(D) 237.5%

**Question Number : 60**

**Correct : 1 Wrong : -0.33**

The following sequence of numbers is arranged in increasing order: 1,  $x$ ,  $x$ ,  $x$ ,  $y$ ,  $y$ , 9, 16, 18. Given that the mean and median are equal, and are also equal to twice the mode, the value of  $y$  is

(A) 5

(B) 6

(C) 7

(D) 8

**Question Number : 61**

**Correct : 2 Wrong : -0.66**

The old concert hall was demolished because of fears that the foundation would be affected by the construction of the new metro line in the area. Modern technology for underground metro construction tried to mitigate the impact of pressurized air pockets created by the excavation of large amounts of soil. But even with these safeguards, it was feared that the soil below the concert hall would not be stable.

From this, one can infer that

- (A) the foundations of old buildings create pressurized air pockets underground, which are difficult to handle during metro construction.
- (B) metro construction has to be done carefully considering its impact on the foundations of existing buildings.
- (C) old buildings in an area form an impossible hurdle to metro construction in that area.
- (D) pressurized air can be used to excavate large amounts of soil from underground areas.

**Question Number : 62**

**Correct : 2 Wrong : -0.66**

Students applying for hostel rooms are allotted rooms in order of seniority. Students already staying in a room will move if they get a room in their preferred list. Preferences of lower ranked applicants are ignored during allocation.

Given the data below, which room will Ajit stay in?

Names	Student seniority	Current room	Room preference list
Amar	1	P	R, S, Q
Akbar	2	None	R, S
Anthony	3	Q	P
Ajit	4	S	Q, P, R

- (A) P                      (B) Q                      (C) R                      (D) S

**Question Number : 63**

**Correct : 2 Wrong : -0.66**

The last digit of  $(2171)^7 + (2172)^9 + (2173)^{11} + (2174)^{13}$  is

- (A) 2                      (B) 4                      (C) 6                      (D) 8

**Question Number : 64****Correct : 2 Wrong : -0.66**

Two machines M1 and M2 are able to execute any of four jobs P, Q, R and S. The machines can perform one job on one object at a time. Jobs P, Q, R and S take 30 minutes, 20 minutes, 60 minutes and 15 minutes each respectively. There are 10 objects each requiring exactly 1 job. Job P is to be performed on 2 objects, Job Q on 3 objects, Job R on 1 object and Job S on 4 objects. What is the minimum time needed to complete all the jobs?

- (A) 2 hours                      (B) 2.5 hours                      (C) 3 hours                      (D) 3.5 hours

**Question Number : 65****Correct : 2 Wrong : -0.66**

The bar graph below shows the output of five carpenters over one month, each of whom made different items of furniture: chairs, tables, and beds.

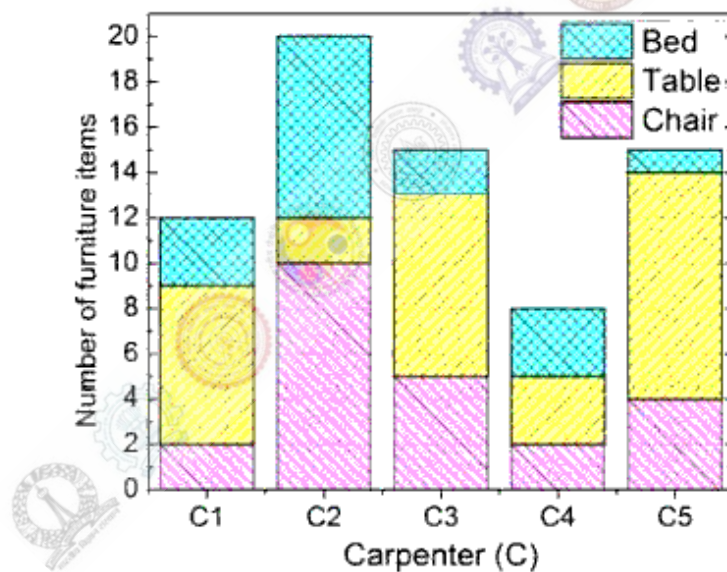

Consider the following statements.

- The number of beds made by carpenter C2 is exactly the same as the number of tables made by carpenter C3.
- The total number of chairs made by all carpenters is less than the total number of tables.

Which one of the following is true?

- (A) Only i                      (B) Only ii                      (C) Both i and ii                      (D) Neither i nor ii